



Care Labs Inc. Product Catalog



Made in America

Toll free: 800-835-9501

281-835-9600

support@carelabs.com

Fax: 281-835-8900

www.carelabs.com

Welcome to Care Labs, Inc.

You have discovered a unique source for high quality cleaning and sanitation products, related dispensers and housekeeping hardware.

We Go Beyond Making a Sale: We are not only confident in our products, but in the latest and most effective methods of sanitizing and cleaning your facilities in different environments. We offer unmatched support for the best cleaning methods with our products.

Buy Direct & Eliminate the Middle-Man: Care Labs, Inc. is a manufacturer and distributor. Buying direct has many advantages to you including lower prices, fresher products, and faster order processing.

A Tradition of High Quality: Care Lab's specialty is high concentrates which, when combined with well-engineered dispensing and application methods, minimizes human related variables. Latest technology components reduces labor and improves results.

Distributor of Quality Products: Care Labs offers a full range of carefully selected, fine quality national and regional brand cleaners, disinfectants and chemical specialties. Our complete line includes a wide variety of maintenance hardware and tools to provide you with an unbeatable single source for all of your sanitation requirements.



Care Labs Inc. Value Added Services

- Technical support – free email/phone consultations for your Care Lab's products.
- General information – other vendor's product failure? / questions about improving sanitation? Call us, we'll try to help with practical solutions.
- Inventory Control – reduce your overhead. We help you minimize over-stocking, product duplications, function overlap, and ways to detect product waste in your facility.

OUR MISSION: We are fully committed to building a long-term business relationship with you based on absolute integrity and a record of surpassing our customer's expectations.

TABLE OF CONTENTS

Aerosols / Air Fresheners.....	Pgs. 4-5
Cleaners - General, Degreasers, Descalers.....	Pgs. 6-10
Disinfectants.....	Pgs. 11-13
Dispensing Systems.....	Pgs. 14-17
Drain Opener / Deodorizers.....	Pg. 18
Gloves.....	Pg. 19
Floor Maintenance / Cleaning.....	Pgs. 20-24
Hand Soaps/ Sanitizers.....	Pgs. 25-27
Hardware Items.....	Pgs. 28-29
Insecticides.....	Pgs. 30-31
Liners.....	Pgs. 32-35
Mattress Sanitation.....	Pg. 36
Odor Digester / Eliminator.....	Pg. 37
Paper Goods (towels, toilet tissue, wipes, etc.).....	Pgs. 38-40
Specialty.....	Pg. 41
Sanitizers.....	Pg. 42
Wipers.....	Pg. 43



Need help looking for a product? Need support?
Email us at support@carelabs.com or call us at 800-835-9501.

BUG BUSTER (#AI41) Insect killer. A water-based insecticide formulated with the synthetic pyrethroid, Resmethrin and Esbiothrin SBP-1382® to be highly effective on flying and crawling insects. The powerful mist spray provides a wide coverage with fast knockdown. A cherry blossom fragrance makes it pleasant to use. This product is an excellent choice for use in food handling and processing facilities. Can be used for both inside and outside applications. USDA F1.

DOWN AND OUT (#AI31) Flying and Crawling Insect Killer. In the air and on the ground, a variety of insect species can be controlled with this pleasantly scented, water-based product. Easy-to-use, convenient, and effective. Down & Out controls over 15 types of insects including flies, mosquitoes, crickets, roaches, ants, carpet beetles, gnats, and spiders. For flying insects, close off the room, spray in a sweeping motion, return in 15 minutes and ventilate the room. For crawling insects, spray directly on the surface, paying particular attention to cracks, crevices, and hard-to-reach areas.



HEALTHCARE DISINFECTANT SPRAY (#ADS11) Tuberculocidal- Disinfects HIV-1 (AIDS Virus) on inanimate environmental surfaces. Also disinfects Herpes Simplex virus types 1 and 2 on inanimate environmental surfaces. In addition, it carries all claims listed for other disinfectant sprays. For use in health care settings such as hospitals, nursing homes, schools, and institutions. 20 oz. can, 15.5 oz. net. Wt., USDA C1.



LUSTRE™ (#AMP11) A superior stainless steel polish and cleaner. Cleans, polishes, and protects stainless steel without hard rubbing or polishing. Resists finger prints, grease, and water spatter. Helps preserve the factory finish. Use on all types of stainless steel windows, frames, trim, doors, corridor guards, kick plates, autoclaves, dishwashers, refrigerators, freezers, sterilizers, elevators, escalators, etc. Also excellent for formica, porcelain, ceramic tile, and chrome.

PENI-LUBE (#AL61) Penetrating Oil. This heavy duty penetrant is designed to work fast. It loosens rust and corrosion, making it easy to separate parts where there is metal to metal contact. This non-conductive formula with moisture displacer lubricates and never dries. Just spray it on locks, hinges, or wherever there are moving parts which have become stationary due to corrosion.

SOLVENT CLEANER AND DEGREASER

(#AS31) For institutional, commercial, and industrial use. This versatile heavy duty cleaner and degreaser works in many types of applications. Its high volume spray loosens dirt, grease, and soil. Just spray and wipe clean. Use on fork lifts, diesel engines, air compressors, alternators, bearings, chains, electrical components, gears, and other heavy duty equipment. Excellent on oil stains, tar, adhesive marks, crayon, lipstick, and fresh paint. Will not short motors, generators, or other electrical equipment. Electric motors and generators may be cleaned while in use. Meets Standard Spec. ASTM D4080-96. Cannot be used on plastics. Contains no ozone depleting chemicals.

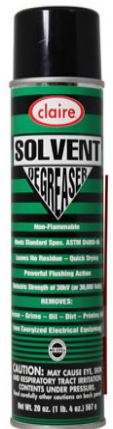

Environmentally-Safe

Aerosol cans sold by Care Labs, Inc. are 100% recyclable. Ten percent of aerosol cans are made from aluminum, one of the most widely recycled metals in the world. Even more impressive, the other 90% are made from steel, the easiest material of all to recycle due to its magnetic separation properties. In addition, aerosol cans in the U.S. contain over 25% recycled steel completing the recycling loop.

Air Fresheners, Metered

FRESH LINEN, METERED (#AFT20)

Formulated with Ordenone™ Odor Neutralizer.

Ordenone does not mask the odor, but eliminates it.

Eliminates smoke and other malodors. Effective in areas up to 6000 cubic feet. Contains more than 3000 metered releases. Dry formula means no messy fall-out on counters and floors.

Fresh Linen Fragrance.

12 cans/case

Our most popular fragrance



METERED DISPENSER, (#AFTD):

Uses 2 “C” batteries

Approximately 8.5” tall

Lasts over 1 year depending on settings

Slim, compact dispenser with a variety of features and functions to meet your odor elimination needs.

Key lock mechanism

3 Interval settings (7.5, 15 & 30 minutes)

24 hour/night/day

Red light signals empty can



MEGA MANGO, METERED (#AFT22)

Formulated with Ordenone™ Odor Neutralizer.

Ordenone does not mask the odor, but eliminates it.

Eliminates smoke and other malodors. Effective in areas up to 6000 cubic feet. Contains more than 3000 metered releases. Dry formula means no messy fall-out on counters and floors.

Fresh Linen Fragrance.

12 cans/case

Our most popular fragrance



Air Fresheners, Manual-Spray

GLEME MALODOR, 20 OZ (#AD11):

Available in a 10 oz. can

No wet fallout

No residue or staining

Neutralizes tobacco odors

Deodorizes air

12 cans/case



CARE KNOCKOUT™ DEODORIZER(#LDCXX):

A powerful, broad-spectrum deodorizer which quickly and effectively eliminates the most severe odor problems. KNOCKOUT™ is economical and also an excellent environmental choice. One gallon does the work of 12 or more aerosols. This saves in product use-cost, inventory overhead, storage space and it reduces the number of discarded containers which go to landfills. Our dispensing system eliminates the use of flammable or ozone-depleting propellant gases. In addition, our adjustable spray pattern nozzle is a convenient advantage in many applications.

Available in the following fragrances:

Fresh: #LDC10

Cherry: #LDC2

Baby Powder: #LDC4

OTHER METERED FRAGRANCES AVAILABLE:

Mulberry Breeze: #AFT23

Country Garden: #AFT26

Rain Forest: #AFT27

Cucumber Melon: #AFT28

Upon Special Request:

Baby Powder

A Touch of Vanilla

Tropic Breeze

Cleaners - General



Glass Cleaner

BRITE™ (#LC1) BRITE™ is an industrial strength product designed to satisfy all requirements of an effective and versatile glass cleaner. Ready-to-use; no dilution required.

Sold in quarts.

BRITE PLUS™ (#LC3) Glass Cleaner Concentrate. The economical answer to all glass cleaning needs. Concentrated; requires dilution. Brite Plus™ in non-ammoniated and contains detergents, degreasing, and drying agents. Sold in gallons.

WINDEX GLASS CLEANER (#LC4) Cleans with Ammonia-D for a streak-free shine. The grease-cutting ingredients and surfactants loosen soil upon contact. Starts to clean before you even start to wipe. For cleaning a variety of hard surfaces. Use gallon bottle to refill smaller bottles.

Sold in quarts.

Other Cleaning Chemicals

E-Z WASH™ (#LDW1) E-Z WASH™ Detergent Concentrate is a multi purpose liquid dish wash product specially formulated for use in the food industry environment. E-Z WASH™ does not contain harsh acids or alkaline detergents and may be used in all areas of the food processing plant. USDA A1.

Sold in gallons and pails.

GENIE™ (LBC1) GENIE™ is a complete bathroom cleaner. This product cleans toilets, sinks, tubs, showers and related fixtures fast and efficiently. GENIE™ is the product of choice for tough bathroom cleaning jobs. GENIE™ is pleasant to use and economical. GENIE™ is concentrated and effective.

Sold in quarts with flip-top caps for easy dispensing.

TILE BRITE (LD5) Tile and Fiberglass Cleaner. The easy, economical way to maintain shower tile, vitreous china and fiberglass bathroom fixtures. Tile Brite™ removes corrosion, oxidation, soap film, lime, and hard water stains from vitreous and fiberglass fixtures, shower tile, drinking fountains, glass, and cement grouting. Tile Brite™ acts quickly and provides thorough penetration and removal of stains and deposits with minimal labor. Sold in quarts. (Special request item; minimum order requirement)



Cleaners - Laundry Detergent



ALPINE™ (LL2) Liquid laundry detergent concentrate. A commercial liquid laundry detergent concentrate with optical brighteners for whiter whites and enhanced colors after laundering. ALPINE™ Liquid Laundry Detergent Concentrate is formulated to remove grease, grass stains, dirt and other tough soils while leaving clothes bright and freshly scented. ALPINE™ Liquid Laundry Detergent Concentrate is formulated for use in commercial, industrial and institutional laundries. This high quality detergent performs well in all water temperatures and is safe for all machine washable items.



For regular washers, use 4 ounces per 100 lb load. For High Efficiency (HE) washers, use 1-2 ounces per load. Sold in gallons, pails, kegs, and drums.

NICE 'N CLEAN LAUNDRY DETERGENT. 50 lb Box. Powdered laundry detergent. Made by Arcot Manufacturing Company.

PURE BRIGHT GERMICIDAL BLEACH (LG3J). 6-1 gal Bottles per case. Pure Bright Professional Cleaning Products are specifically formulated for the tough cleaning needs of institutions and industrial cleaning settings, including clinics, hospitals, fitness clubs and restaurants.



ALKADET™ (#LC13) Heavy Duty Cleaner. ALKADET™ is a self foaming heavy duty alkaline detergent designed for use in meat and poultry plants, food processors and in some industrial applications. Self foaming, versatile, fast acting, and economical. USDA approved. Sold in pails, kegs, and drums.

AMIGO™ (#LSC6) Amigo is an organic multipurpose degreaser and deodorizer. Amigo does an outstanding job of removing grease, oil and similar soils from most surfaces.

Amigo may be used in hospitals, nursing homes, schools, durable medical equipment rental centers, restaurants, industrial plants or wherever accumulations of greasy residues present a challenge.

Amigo does an excellent job of removing residues of de-laminated tape, decals, chewing gum, tar, tire marks, many types of marks-a-lot and other industrial and vandalism marks.

Sold in quarts, pails, and kegs.



BLITZ™ (#LSC5) Waste System Degreaser/Deodorizer. A versatile product suitable for many grease cutting and deodorant applications. For specific product information and customized recommendations, please contact Support at support@carelabs.com and a representative will be in touch with you as soon as possible. USDA C1.

Sold in gallons, pails, kegs, and drums.

EXCEL™ (#LC10) General Equipment and Environmental Surfaces Cleaner. Excel™ achieves superior results in the removal of even tenacious soils in food process operations. Excel™ will effectively remove heavy accumulations of fats, grease, blood, dirt and other oily soils with ease.

Sold in gallons, pails, kegs, and drums.

Excel™ has been formulated to utilize the latest surfactant technology, is versatile and often replaces several specialty products used in cleaning operations. Excel is highly concentrated, non flammable and non corrosive. USDA approved.



HAUS KLENZ™ (#LC5) Self-Foaming Smoke House Cleaner HAUS KLENZ™ provides clinging foam combined with a powerful cleaning complex to provide speedy removal of all types of carbonized grease, fats, food and similar soils from stainless steel and other alkaline resistant surfaces.

HAUS KLENZ™ is a complete smoke house cleaner. No additional products to buy or mix. USDA approved.

Sold in pails, kegs, and drums.



ONE STEP MS™ (#LGC3) ONE STEP MS is a heavy duty, self foaming, liquid alkaline chlorinated cleaner designed for use in the food processing industry. ONE STEP MS is a powerful de-stainer and heavy duty cleaner which will remove grease, oils, blood, protein and other food soils from food processing equipment and environmental surfaces. ONE STEP MS is effective in hard water. USDA approved.

SSS SPRAY OIL (#LPC3G) Spray Oil is an excellent protective anti-rust agent when sprayed on food processing equipment. SSS Spray Oil can also be used as a release agent on gaskets or seals of tank closures, and as a lubricant for machine parts and equipment. SSS Spray Oil is suitable for use in locations where there is potential exposure of the lubricated part to food. Authorized by USDA for use in federally inspected meat and poultry plants.
Sold in gallons.

NEW DISPENSER NOW AVAILABLE!

CARE LABS, INC. is now introducing our Niftee 2.0 Foamer/Sprayer system for automatic dispensing of Care Labs products at the correct dilution rate. Read more about the new system in our Dispensing section.



LIGHTNING™ Detergent Scone Remover LIGHTNING™ is a highly concentrated acidic detergent and brightener formulated for use in the laboratory research environment. LIGHTNING™ excels in the removal of uric deposits, animal excreta, hard water scale and other soils from stainless steel. Sold in gallons, kegs, and drums.

SCONEX™ (#LD6) A highly concentrated acidic detergent and brightener formulated for special research environments. Sconex™ excels in the removal of uric deposits, animal excreta, hard water scale and other soils. Sconex™ also removes soap scum, organic and inorganic matter from ceramic tile floors, walls, and fixtures. Sold in gallons.

SG 57™ (#LD32) SG 57™ effectively dissolves calcium carbonate and other hard water scales wherever accumulations occur. SG 57™ is an effective and proven acidic detergent and descaler. This free rinsing, highly concentrated product, wets, penetrates and suspends organic soils. USDA approved. Sold in gallons.

** COMPARE FAUCET BEFORE & AFTER CLEANING WITH SG 57™ **

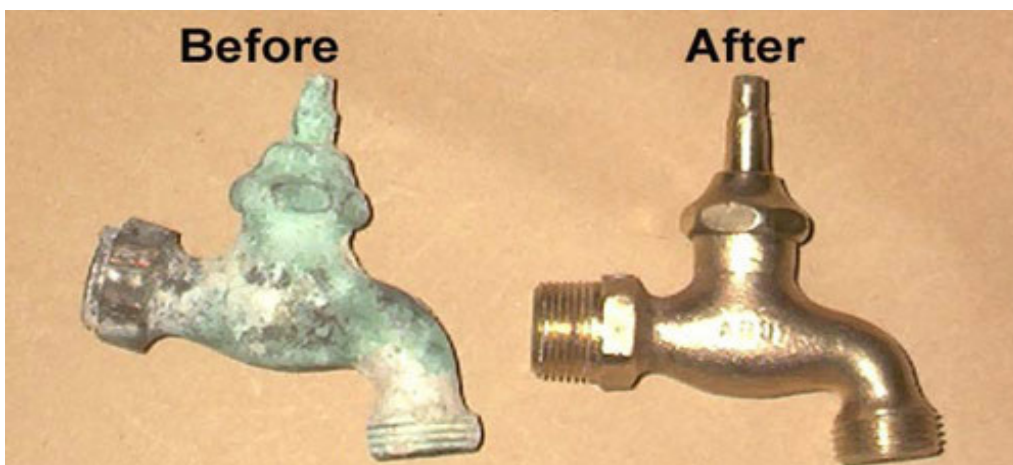

Disinfectants



BIOCIDE PLUS™ (#LGC1) A concentrated, multi-purpose, neutral pH, germicidal detergent and deodorant effective in hard waters up to 400 pp, (calculated as CaCo3) in the presence of a moderate amount of soil (5% organic serum) according to the AOAC Use-Dilution test. Disinfects, cleans, and deodorizes in one labor saving step.

1. **CLEANER:** Easily removes very tough soil residues and their related odors.
 2. **DEODORIZER:** Long lasting Ocean Fresh scent; **ELIMINATES ODORS!**
 3. **MILDEWSTAT** (on hard inanimate surfaces): Controls mold and mildew.
 4. **VIRUCIDE:** Kills Influenza A (Canine Influenza)! Kills HIV-1 (AIDS). Kills Hepatitis B Virus (HBV) and Hepatitis C (HCV). Kills Parvovirus, Canine Distemper virus, Feline Picornavirus, and much more!
 5. **DISINFECTANT:** Kills Staph, Salmonella, Psuedomonas and E. Coli.
 6. **FUNGICIDE** (against pathogenic fungi)
 7. Efficacy tests demonstrate that Biocide Plus™ is effective in the presence of organic soil. (5% blood serum)
 8. **SAFE:** Non-Dulling to Floors - Floor Finishes (neutral pH); Environmentally preferred and safe to the environment.
 9. **ECONOMICAL:** Clean for \$.15/gallon Biocide Plus is highly concentrated and has a very low usage cost. Ready-to-use and weakly concentrated products are NOT the solution for large cleaning and disinfecting jobs.
- Sold in gallons, pails, kegs, and drums.



For more information, visit www.carelabs.com/biocide-plus.html

PURE BRIGHT GERMICIDAL BLEACH (LG3J). 6-1 gal Bottles per case. Pure Bright Professional Cleaning Products are specifically formulated for the tough cleaning needs of institutions and industrial cleaning settings, including clinics, hospitals, fitness clubs and restaurants.



See next page for more disinfectant products.

Disinfectants (Cont.)

SPRITZ™ (#LGC2) *INTERMEDIATE-LEVEL DISINFECTION* (Most disinfectants are low-level.) Detergent disinfectant. Decontaminates surfaces three ways leaving them thoroughly cleaned, disinfected and deodorized. Controls cross contamination from treated surfaces. It is an excellent toilet bowl cleaner when dispensed through our #T125 Flip Caps for quart bottles. Check for container sizes.

1. **CLEANER:** Easily removes very tough soil residues.
2. **DEODORIZER:** Long lasting Irish Rose scent provides delightful “clean and fresh” residual fragrance.
3. **MILDEWSTAT** (on hard inanimate surfaces): Controls mold and mildew.
4. **VIRUCIDE:** Kills HIV-1 (AIDS). Kills Hepatitis B Virus (HBV) and Hepatitis C (HCV). Kills Parvovirus.
5. **DISINFECTANT:** Kills Staph, Salmonella, Psuedomonas and E. Coli.
6. **TUBERCULOCIDAL:** Excellent for Blood Borne Pathogen compliance programs.
7. **FUNGICIDE** (against pathogenic fungi): Use in shower stalls, locker rooms.
8. Efficacy tests demonstrate that Spritz™ is effective in the presence of organic soil. (5% blood serum)



SPRITZ™ is designed specifically as a general non-acid cleaner and disinfectant for use in hospitals, schools, office buildings, manufacturing facilities, lodging establishments, veterinary clinics, pet shops, animal life science laboratories and athlete/recreational facilities where housekeeping is of prime importance in controlling the hazard of cross contamination. Sold in quarts, pails, and kegs.

STERI-FAB (#LG8) Steri-Fab is an all around great product for your sanitary maintenance needs. It provides an easy method for cleaning that can replace many single-use products. STERIFAB is a viricide, bactericide, sanitizer, fungicide, insecticide, germicide, deodorizer, disinfectant, mildewcide, bacteriostatic and fungistatic all in one, eliminating the need to keep many different single-use products on hand. STERIFAB kills bed bugs fast and dries crystal clear in 15 to 20 minutes with absolutely zero messy residue.

Sold in pints, gallons, and pails. (Pails are special order items.)



Disinfectants (Cont.)

Specialty

CAVICIDE (#M801) Surface Disinfectant/Decontaminant Cleaner. CaviCide is a convenient, ready-to-use, intermediate-level surface disinfectant which is effective against TB, HBV, HCV, viruses (hydrophilic and lipophilic), bacteria (including MRSA and VRE) and fungi. It is safe for all areas of the facility including NICU, operating rooms, isolation rooms, patient care areas and laboratories. When used as directed, it will also effectively clean and decontaminate critical and semi-critical instrumentation.

CaviCide is safe for use on non-porous surfaces. It is perfect for cleaning and decontamination of environmental and medical device surfaces.

Sold in gallons (Quarts available, but are considered a special order item).



METRICIDE 28 DAY (#M824) High-Level Disinfectant and Sterilant.

MetriCide 28 is a long life, 2.5% buffered glutaraldehyde that can be used and reused as a sterilant and high-level disinfectant for up to 28 days.

Features

1. Recommended for immersible and heat-sensitive equipment and instruments
2. Contains a surfactant
3. No dilution required



NIFTEE™ HAND HELD FOAMER FOR CLEANING

(#F500 OR #F501) A unique injection concept mixes the proper amount of concentrate with both air and water to produce thick, rich foam for longer soak time. Available in capacities of 96 ounces (#F500) or 48 ounces (#F501). 96 ounces = 2.8 liters 48 ounces = 1.4 liters

NIFTEE™ HAND HELD SPRAYER FOR SANITIZING

(#F502) Our sprayer system is very similar to the foaming unit, but it does not create foam. Sprayer produces a fine, mist spray suitable for application of products that do not require foaming action.



The foamer below is recommended for high water pressure environments only:

***NEW* NIFTEE PLUS FOAMER (#F600)** is a unique medium volume hose-end foam gun for diluting and applying foaming chemicals to any surface. This unit uses standard city water pressure to draw chemical concentrate from the attached bottle and blend it into the water stream. The accurately diluted solution flows through the foam wand to create a clinging, wet foam which is then projected on to any surface up close or at distances up to 12 feet.



See page 15 for more dispensing products.

The following parts are for the Niftee Foamer first generation (#F500, #F501, #F502):

Foamer Parts List

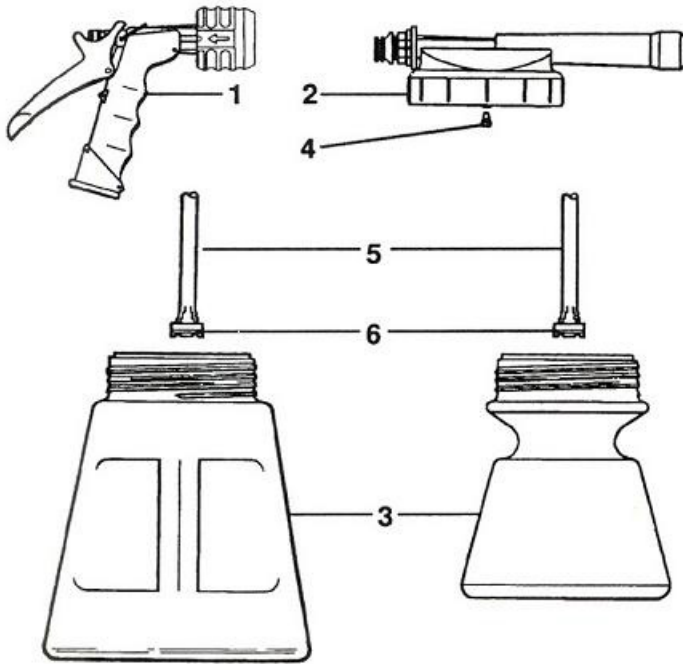

Key	Part No.	Description
1	F520	Spray Gun & quick disconnect
2	F524	Foamer lid assembly
3	F527	Foamer bottle, 96oz
3	F526	Foamer bottle, 48oz
4	F512	Metering Tip
5	F522	Suction tube, 8"
6	F523	Foot strainer

Description	Stock No.
Foamer, 96oz	F500
Foamer, 48oz	F501
Sanitizer, 48oz	F502



P.O. Box 637
 Missouri City, TX 77459-0637
 Phone: 281-835-9600 800-835-9501
www.carelabs.com

*The Niftee Sanitizer Sprayer lid assembly Part No.: #F524S.

Metering Tips

BIOCIDE PLUS METERING TIP (MAROON): #F508

BIOCIDE PLUS PARVO METERING TIP: #F509

SUR-SAN METERING TIP: #F511

ZAPS IT METERING TIP: #F512

*For non-germicidal products like Excel, Bull Dog, Haus Klenz, etc. please contact us for consultation on the best metering tip based on the desired cleaning applications.

Dispensing Systems (Cont.)

***NEW* CARE MULTI-FLEX (#D319)** The MultiFlex Series delivers the flexibility to customize and configure multiple products from multiple packaging shapes and sizes, and provides the flexibility to configure the system as it works best for your application.

A great option for Biocide Plus customers!

ONE DISPENSER does it all - ACCURATE dilutions for every common use:

- *Fill spray bottles with broad-spectrum dilutions
- *Flip a switch and get a heavy cleaning (Parvocidal) strength solution
- *Fill mop buckets and tank sprayers quickly with the high-flow option

We are proud to introduce a new innovation which helps dilute chemical concentrates into individually selectable solution strengths. Each mixture is best suited for particular tasks.

All you do is choose the setting for a particular task and then begin your work. This flexibility optimizes efficacy of cleaning solutions, helps reduce labor, and virtually eliminates unnecessary waste of chemicals.

- *One dispenser, many applications
- *Eliminates manual dilution (product misuse)



***NEW* CARE MOBILE CLEANING SYSTEM.** a self-contained low volume Foam/Rinse/Sanitize cleaning system for multiple chemical applications. This convenient system uses a re-chargeable battery and 12V pump to draw fresh water from the 16 gallon tank and create the pressure to run the system. It uses precision metering tips to accurately dilute two chemical concentrates from the attached jug rack and projects one chemical as wet foam, a second as a fan spray, and rinses. Perfect for precision cleaning in small areas where water pressure is unavailable.

Key Features

1. Completely self-contained Foam/Rinse/Sanitize system
2. Powered by a rechargeable battery and 12V pump
3. Projects wet, clinging foam, chemical spray and rinses in a fan pattern for quick coverage
4. Micro-Flow Injector restricts water flow to maximize run time per tank
5. Unique machined polypropylene suction lids prevent spillage from chemical bottles
6. Heavy-duty EZ trigger gun with stainless steel quick disconnect for switching between foam and spray nozzles
7. Adjustable Bullet foam nozzle (spray/stream)
8. Non-marking tires



CARE CONTROL UNIT (#D325) An easy and economical solution for dispensing chemicals to a mop sink (disinfectant) or 3-compartment sink (sanitizer). This unit is easy to install and easy to maintain.

Ideal for use with Biocide Plus (mop sink) or Sur-San (3 Compartment Sink).



HANDEE™ PUMP UP SPRAYER (#F515) Portable, heavy-duty pump-up sprayer for dispensing cleaning solutions in areas with no water hose connection. The economical choice to a mobile cleaning system.



PUMP, ONE-OUNCE DELUXE GALLON/PAIL (#T100/T105) One-ounce pumps to fit on top of a gallon concentrate or a pail. Dispenses one ounce of product per pump.



PUMP, PAIL/DRUM 8 OZ. LIFT (T115) • Adapts to both 3/4" and 2" National Pipe Thread; fits 5, 15, 20, 30, & 55-gallon drum with 2" National Pipe Thread • polypropylene and polyethylene construction for chemical resistance

- special pail adapter included, fits 5 or 6-gallon pails with Senior Rieke FlexSpout
- pumps 8-oz., or 2, 4, or 6-oz. • chemical resistant O-ring for better seal



* **DRUM PUMPS:** More options available (siphon pumps, metal drum pumps, etc.) Contact us for more information.

SPECIALIZED WALL MOUNTED SYSTEMS: Eliminates manual mixing and optimizes chemical utilization, employee safety and labor efficiency for multiple chemical products.

Care Labs offers a full line of specialized wall-mounted systems. Contact us today to discuss your specific needs.



Drain Openers

MISTY® HALT LIQUID DRAIN OPENER (#1AMRR993-12) Powerful, nonfuming, highly concentrated alkaline-based formula. Clears clogged drains of organic matter, hair, paper, grease and oils. As a drain maintainer, it keeps drain lines clear and free-flowing to reduce offensive odors. Commercial grade. Includes 12 1-quart bottles per case.



Drain Deodorizers

BLITZ™ (#LSC5) Waste System Degreaser/Deodorizer. A versatile product suitable for many grease cutting and deodorant applications. For specific product information and customized recommendations, please contact Support at support@carelabs.com and a representative will be in touch with you as soon as possible. USDA C1. Sold in gallons, pails, kegs, and drums.

ZAPS IT (#LE2) ZAPS IT™ is a powerful odor digester and organic stain remover. ZAPS IT™ dissolves and digests waste residues, stains and malodors caused by urine, feces, vomit, blood, food wastes and other organic matter. It was created utilizing the best bio-technology and modern chemistry to build a product that achieves successful results where other products may disappoint or fail to perform. Sold in quarts, gallons, and pails.

ZAPS-IT™ is NOT simply a deodorizer. ZAPS-IT™ is a blend of friendly bacteria which remain inactive in the bottle. When sprayed on a problem area, the solution penetrates into porous surfaces, grouting, cracks and hard to reach areas. Upon contact with residues of urine, feces, vomit, blood, food soils and other organic wastes enzymes begin breaking down the odor-forming organics into liquids. The bacteria then convert the absorbed organics into carbon dioxide and water which quickly dissipate. While this process is taking place, the pleasant fragrance of ZAPS-IT™ provides immediate relief from bad odors.



Gloves

Medical, Latex

GLOVES, LATEX EXAM POWDERED(#G100)

Powdered
Low Protein
Low Allergen
Soft Modulus
Fits like second skin
1M/case



GLOVES, LATEX EXAM PWD-FREE(#G300)

100% Powder Free
Low protein
Fully textured for confident gripping on wet surfaces
Greater thickness to increase protection and prolong shelf life

GLOVES, HIGH RISK LATEX POWDER-FREE EXAMINATION (#G800)

Twice as thick
Fully Textured
Powder Free
12" long
13 mils
500/case



Medical, Latex-Free

GLOVES, POWDER-FREE NITRILE EXAMINATION (#G600)

100% Latex Free
New Grape Color
Powder-Free
Textured
Chemo Approved
Accelerator Free
1M/case



*The gloves listed on this page are the most commonly purchased gloves that Care Labs, Inc. typically carries in stock. However, it is not the complete line. If you would like us to stock and quote a specific glove that you do not see in our listing, please contact us at 800-835-9501 and we will get you a quote and add the glove to our stocked line.

Non-Medical, Latex

GLOVES, LATEX POWDER-FREE(#G699)

USDA accepted for food use
Powder-Free
Low allergen
Fully textured for confident gripping of wet surfaces
1M/case

Non-Medical, Non Latex

GLOVES, STRETCH SYNTHETIC POWDERED (#G2199)

100% Latex Free
Feels like latex
Powdered
Stretch synthetic
1M/case
*Available in non-powder



GLOVES, VINYL DISPOSABLE (#G799)

USDA accepted for food use
100% Latex Free
Lightly powdered with U.S.P. absorbable cornstarch
Designed for non-medical application



GLOVES, VINYL POWDER-FREE DISPOSABLE (#G899)

USDA accepted for food use
100% Latex Free
Powder Free
Advanced polyvinyl chloride formulation
Designed for non-medical applications



Hard Floor Maintenance

CYCLONE (#LC16)[™] Auto Scrub Concentrate For Industrial Floors. Cyclone[™] is the product of choice for use in all automatic floor scrubbing machines. Cyclone[™] is low foaming for quick, easy pick up and is highly concentrated for maximum economy in use dilution. Check for container sizes. Cyclone[™] is formulated to remove heavy soils and grease from brick, ceramic tile, concrete, and terrazzo floors. When used as directed is safe for use in contact with floor scrubber parts and will not clog valves, pipes, or orifices in the scrubbing machine. USDA A1.

FAST STRIP (#LWS5)[™] This product is a concentrated, heavy duty, non-ammoniated **wax stripper**. Use on resilient tile, terrazzo, and concrete floors. Do not use on wood or cork floors. Strips off all wax and polymer finishes. Low foaming makes this product ideal for use with automatic floor scrubbers or wet mopping applications. Removes stains, black heel marks and rubber burns while scrubbing. Sold in 5-gallon pails.

POLY-REX (#LW4)[™] **Floor finish**. A new generation floor finish for resilient tile floors. Field test evaluations confirm this product has the highest level of gloss, combined with superior durability. Excellent response to burnishing; detergent and water resistant. Meets or exceeds the requirements for floor finish slip resistance as measured by the A.S.T.M. Test Method D2047. Sold in pails.

BIOCIDE PLUS(#LGC10)[™] **Nuetral Floor Cleaner/Disinfectant**. A concentrated, multi-purpose, nuetral pH, germicidal detergent and deodorant. Sold in gallons, pails, kegs, and drums.



Hard Floor Maintenance - Buff / Burnish

RED BUFFING PAD (#M4044): For light cleaning and buffing. Removes light scuff marks and dirt while producing a high gloss shine.

Available in sizes: 6" THROUGH 31"

IMPRESS BURNISHING PAD (#M4035): UHS burnishing pad with an ultra soft feel that allows you to burnish between coats of floor finish. Will create amazing shine without the 24 hour wait for curing. Ideal on finishes ranging from soft to hard.

FOR USE ON MACHINES UP TO 3000 RPM.



Hard Floor Maintenance - Scrub Pads

CARE SWIVEL PAD & HOLDERS: The Octopus pad and holder system are the ideal cleaning tools for reaching hard to get at places like baseboards, stairs, under fixtures and furniture. Hundreds of tiny hooks on the base of these holders secure the utility pad firmly in place. The pad simply peels away from the holder for reversing or replacing.

Lockon Swivel Pad Holder: #F406
Heavy-duty brown pads: #F407BR



Hard Floor Maintenance - Strip Pads

DOMINATOR EXTRA HEAVY DUTY AGGRESSIVE STRIPPING PADS (#M4305): Designed specifically for the heaviest duty stripping tasks. This pad is made with extra heavy denier fiber, more abrasive grit, and more open weave to produce the ultimate stripping pad.

Available in sizes: 6" THROUGH 31"

HEAVY DUTY BLACK STRIPPING PADS (#M4005): Extra aggressive pad. Excellent for removal of burnished floor finishes.

Available in sizes: 6" THROUGH 31"

BROWN STRIPPING PADS (#M4002): Designed for wet or dry stripping applications. Aggressively removes wax, dirt, and old finish, leaving surface ready for refinishing. For use with machines up to 350 RPM

Available in sizes: 6" THROUGH 31"





Carpet Maintenance

EXPRESS (#LC11)™ Fast acting steam cleaner. A powerful cleaner specifically formulated for use in steam and high pressure cleaning equipment. Express™ goes to work fast to remove even the most tenacious soils; it is water soluble, free rinsing, and effective in hard water. Sold in pails.

STERI-FAB (#LG8)™ Carpet Deodorizer/Sanitizer. Kills odor-causing bacteria and fungi from carpet. Also kills bed bugs, which hide in carpets and other soft surfaces.

Need to deodorize your carpet or kill bed bugs?
Order a Steri-Fab Starter Kit now!



STERI-FAB BED BUG STARTER KIT (#LG8SK)

Order online at: www.carelabs.com/store/sterifab.html



Mopheads

NATURAL LOOPED-END, SADDLE-TYPE, COTTON SYNTHETIC BLEND

(#M166) General purpose cotton synthetic blend for most applications
Tailbanded and looped prevents fraying, linting, and tangling while providing wide surface coverage
Wide headband is vinyl coated mesh
Recommended for laundering



Small size: Special order item (12 mophead minimum)
Medium size: #M166MD
Large size: #M166LG

NATURAL LOOPED-END, SADDLE-TYPE, COTTON SYNTHETIC BLEND, BLUE-COLORED (#M270)

General purpose cotton synthetic blend for most applications
Tailbanded and looped prevents fraying, linting, and tangling while providing wide surface coverage
Wide headband is vinyl coated mesh
Recommended for laundering
Colored to hide dirt from clients



Small/medium size: Special order item (12 mophead minimum)
Large size: #M270LG

REGULAR RAYON WET MOP HEADS, SCREW-TYPE (#M611XX)

Grade 1 yarn for high tensile strength/durability
Rayon material has minimal linting
Ideal for applying floor finish and disinfectants
Mop goes from the bag to the bucket with no break-in period
Excellent absorbency that requires fewer trips to the bucket
Fast release promotes faster drying after use and is mildew resistant
Available with or without no-tangle band
No-tangle band recommended for laundering



#M61116: 16 oz. mop size, 12 mops/case
#M61120: 20 oz. mop size, 12 mops/case
#M61124: 24 oz. mop size, 12 mop/case (also sold by each).
#M61132: 32 oz. mop size, 12 mop/case

HANDLES FOR MOPHEADS:

Jaw-Grip Clamp 54" Fiberglass (#H61): Fits the M166 and M270 series mopheads. Available in a 60" handle (#HWH60).



Screw-type 60" Wood (#H80260): Fits the M611xx series screw-type mopheads. Available in Fiberglass (#H50360).

Mopheads - Microfiber

Mopping represents one of the more popular uses of microfiber material. Using conventional cotton loop mops for wet mopping has long been the standard in floor cleaning for janitorial operations. Here are some key benefits of using microfiber for the mopping task:

1. Enhances cleaning power – microfiber cleans more effectively, reaching into surface pores and crevices, where cotton mop materials are too large for deep cleaning.
2. Contributes to reducing water and chemical usage – microfiber mops use about 10-20 times less liquid than standard cotton mops, helping reduce procurement costs. Very few microfiber applications require the use of chemicals.
3. Helps increase productivity – the effort of dipping and wringing a conventional mop is eliminated. As long as the used microfiber mop head is not put back in the cleaning solution, the user does not have to change the solution between tasks.
4. Helps reduce cross-contamination – healthcare facilities have been quick to embrace microfiber cleaning. In an effort to reduce cross contamination risk between patient rooms, some state laws require that maintenance personnel change out the mop and/or cleaning solution after every room. Using microfiber flat mops helps the facility comply with these requirements.
5. Help reduce the risk of worker injury – microfiber mops weigh significantly less than conventional wet cotton loop mops, making them more ergonomic and easier to use.

MICROFIBER STARTER KIT (#M102) Kit includes: one extension handle, one mop holder, three #M102M 18” scrubber mops, two #M102DM 18” dust mops, two green microfiber cloths, two blue suede microfiber cloths, and one complete high duster.

A great solution to trying out the microfiber mopping system. Care Labs, Inc. has access to different size mopheads and dusters that are available upon request.



MICROFIBER WET SRUBBER MOPS REFILLS (#M102M)

MICROFIBER DUST MOP REFILLS (#M102DM)

Care Labs, Inc. offers many types of hand soaps and sanitizer designed for general use, to E2 certified hand products designed for USDA inspected food plants.

Browse through our products or contact us for more information.

CleanShape Series



Clean Shape® is a versatile dispensing system that provides flexibility and delivers superior performance. The easy-to-use pump bottles are larger than most sink top dispensers and economical – no added cost of a fixture. Portable and disposable, Clean Shape bottles remain stable when pumping and comply with ADA guidelines. The stylish bottle is easy to grip and complements any décor. Snap the bottle into the optional wall bracket to create a wall mounted dispensing system.

CLEANSHAPE INSTANT HAND SANITIZER (#LHS45) No water needed when using this crystal clear, ethyl alcohol based gel. Kills 99.9% of eight important organisms in 15 seconds or less including MRSA, VRE and E-coli, plus, the thick formula won't run off hands and doesn't over-dry skin. No dye or fragrance. Helps employees comply with OSHA's Blood-borne Pathogens Standard. Great for fast hand cleaning.

*Packaged in 1000ml containers, 8 per case.

CLEANSHAPE FOAMING INSTANT HAND SANITIZER (#LHS44) Foaming Instant Hand Sanitizer (**No Alcohol**) is effective and convenient to sanitize hands when soap and water are not available. Formulated with 0.2% Benzethonium Chloride to eliminate 99.9% of common germs within 15 seconds. Enhanced with Aloe Vera and Vitamin E to moisturize skin. More economical, no medicinal odor and does not dry out skin like alcohol sanitizers. Non-flammable and dye free, with a light linen fragrance. Ideal where a non-alcohol product is desired. E-3 rated.

*Packaged in 950ml containers, 8 per case.

CLEANSHAPE FOAMING HAND SOAP (#LHS40) Formulated with 0.5% Triclosan, lab test prove that it kills 99.9% of most disease-causing bacteria. With an amber color, citrus-spice scent and enhanced with Aloe and Vitamin E, this unique foaming formula lathers quickly and leaves hands feeling clean and smelling fresh.

*Packaged in 950ml containers, 8 per case.

See next page for more hand soap products.

Hand Soaps / Sanitizers (Cont.)



JOB ANTISEPTIC (#LHS18) An economical, **general purpose antiseptic soap** which is gentle on your hands. Scientifically formulated with a natural soap base, skin emollients and PCMX to provide gentle, effective cleaning and to kill of a whole variety of disease causing bacteria, viruses, and fungi on contact. USDA E1.



HAIR & BODY SHAMPOO (#LHS22) Shower and Shampoo. A rich, emerald green shampoo and body soap which contains protein supplements to enrich the skin, plus hair conditions. It cleans the hair, makes it more manageable and adds a pleasant scent. Hair & Body Shampoo provides deodorant protection with lots of suds for the body and the air. It provides superior sudsing in soft or hard water and excellent cleansing and deodorant properties. It is pH balanced and contains special conditioners for both the skin and the hair. Hair & Body Shampoo offers a pleasant fragrance and soft lotion feeling with rich emollients to soften the skin. Unlike bar soap, it is not wasteful and eliminates the danger of slipping. Ideal for use in the shower rooms of country clubs, health clubs, spas, swim clubs, tennis clubs, schools, etc.

HEALTH-GUARD (#LHS23D) Antibacterial soap. The extraordinary antibacterial hand soap that stops the spread of germs and disease- DEAD IN THEIR TRACKS! It is an established fact that proper hand washing hygiene in workplaces and public restrooms can help limit the spread of many infectious diseases. However, most liquid soaps contain no germ-fighting, antibacterial ingredients. Therefore, although the hands may look and feel clean, the user is often still host to a thriving colony of disease-causing bacteria. HEALTH-GUARD Antibacterial Soap offers great hand cleaning properties—PLUS—a powerful First Line defense against the spread of germs and bacteria.

*Sold in 800ml cartridges for our E-Z Push Dispensers, 12 per case.

INSTANT HAND SANITIZER(#LHS15D) Antibacterial hand sanitizer. An ethyl alcohol-based waterless product developed to kill germs and sanitize the hands where no washing facilities are available. INSTANT HAND SANITIZER is quick to evaporate, odorless and can be used repeatedly without drying the skin. Independent testing shows this product kills 99.9% of eight important organisms in less than 15 seconds, which lowers the risk of disease. INSTANT HAND SANITIZER is designed for use in Hospitals, Clinics, Labs, Child Care Centers, EMS, Health care facilities, Restaurants, Food Service operations, or any environment where water is unavailable.

*Sold in 800ml cartridges for our E-Z Push Dispensers, 12 per case.

E-Z PUSH DISPENSER (#D390) (Shown in the picture to the right of Sani-Sep and Gel-San). This dispenser is a convenient wall-mounted unit that dispenses HEALTHGUARD and INSTANT HAND SANITIZER They are heavy-duty, easy to install, and economical.



GOJO / Purell Distribution

Care Labs, Inc. distributes GOJO and Purell hand soap/sanitizer items. Here are some of our top selling, in stock items:

GOJO HAND WASH, FOAMING ANTIBACTERIAL (#1GOJ5162-03) Smooth orange foaming hand wash with germ-killing power. FMX-12, 1250 ml Cartridge, Amber Orange, Antibacterial, Luxury Foam, Scent: Blossom
3 Ctg/Ctn



GOJO HAND WASH, ANTIBACTERIAL (#1GOJ9127-12) Contains chlorox-lylenol (PCMX), a broad-spectrum antimicrobial agent. Mild formula helps promote frequent hand-washing while killing germs. 800 ml Bag-In-Box Gold, Antimicrobial, Lotion, Scent: Floral, 12 Ea/Ctn



PURELL HAND SANITIZER, NXT REFILLS 8/CS (#LHS51): Kills 99.99% of most common germs that may cause illness. Works in as little as 15 seconds. No water or towels needed. Specially formulated with moisturizers to leave hands feeling soft and refreshed. Alcohol-based.

NXT, 1000 ml Package, Clear, Gel, Instant, Scent: Citrus, 8 Ea/Ctn



*Care Labs sells a full line of GOJO / Purell items, including dispensers. If you'd like a quote on an item, please contact us.

Hardware Items

Brooms / Brushes

SYNTHETIC CORN BROOM (#B3650):

Chemical and liquid resistant • sustains temperatures to 225 degrees F (intermittent heat) • wood handle

WAREHOUSE CORN BROOM (#B3653):

30% corn/70% rattan • corn broom for all cleaning tasks • great for industrial or janitorial sweeping

ALL ANGLE SCRUB BRUSH(#B236):

- use at any angle; has side bristles
- polypropylene bristles stapled into 10” structural foam block
- use with threaded hole handle
- fountain hole for cleaning with water

*Handle Needed: Use #H3651A (60” Fiberglass threaded handle) or #H6271 (62” Aluminum, metal threaded handle). See pictures under Squeegees/Handles.

Bottles / Sprayers

HELPER BOTTLES(#T121):

Empty quart bottle with a label for writing product information.

TRIGGER SPRAYERS (#T120):

Trigger sprayer for quart bottles and Helper Bottles.

Mop Buckets

RUBBERMAID WAVEBRAKE MOP BUCKET/WRINGER COMBO (#M101):

15-7/10” W x 20-1/10” L x 36-1/2” H, 35 qt
Yellow
Downpress
Plastic/Steel
1 Set/Ctn

Reduces splashing for safety. High efficiency down press wringer. Lasts twice as long as Side Press Combo, 7580-88. Tested to exceed 100,000 wringing cycles. Premium tubular steel and structural web molded plastic. Accepts optional Dirty Water Bucket, 9C74.

*Other models (sidepress, off brands) available upon request.

Squeegee / Handles

DOUBLE BLADE MOSS SQUEEGEE(#S6261):

Acid-resistant
Non-corroding polypropylene frame
Will not scratch floors, baseboards or machinery
Screw-style handle socket
Double blades

18” PLASTIC BRUSH/MOSS FLOOR SQUEEGEE COMBO (#S6263):

- stiff polypropylene bristles for scrubbing action
- brush loosens dirt in grout floors
- foam squeegee removes dirt and solution
- acme threaded socket; screw-style handle socket
- great for foodservice applications
- double blades

STANDARD MOSS FLOOR SQUEEGEE:

Quick and easy removal of liquids
Low cost
Replace whole unit, not rubber only
Use on smooth and irregular surfaces
Galvanized, rust-resistant frame
Double blade
#S7030 only has splash guard and reinforced adjustable handle socket on frame

Available in the following sizes:

18” floor squeegee: #S7018

22” floor squeegee: #S7022

30” Heavy-duty floor squeegee: #S7030

HANDLES FOR SQUEEGEES:

For the S6261 or S6263 use the following handles:

HANDLE, 60” FIBERGLASS THREADED (#H3651A):

Medium quality fiberglass handle for squeegees / All Angle Scrub Brush.

HANDLE, 62” ALUMINUM THREADED (#H6271):

High quality, heavy duty handle for squeegees / All Angle Scrub Brush. 3-Degree tapered aluminum handle with an acme threaded zinc alloy-tip
Universal threaded socket (plastic moss, brush/moss, or galvanized squeegees); Comfortable grip.

(More handles for squeegees on next page.)

Squeegee / Handles (Cont.)

HANDLES FOR SQUEEGEES (Cont.):

For the S7018, S7022, and the S7030, use the following handles:

HANDLE, MOSS SQUEEGEE FIBERGLASS (#H8101):
54" fiberglass handle for squeegees.

HANDLE, TAPERED WOOD SQUEEGEE (#H760):
60" Tapered wood handle for squeegees.

SAFETY FACILITY ITEMS

*For more information on the following items, please contact us.

WASHSTATION, EYE AND FACE (#T140)

EYEWASH REFILLS (#T141)

FIRST AID KIT, 50 PERSON (#T142)

SAFETY GOGGLES (CHEMSPLASH) (#T143)

DUST MASKS (#T144)

BOOT SANITATION MATS (#T145)

QUAT TEST STRIPS (#T602): Test strips to ensure your disinfectant solutions are diluting correctly by testing the quat levels (the active ingredient in disinfectants).

Special Order Hardware Items

Care Labs, Inc. has access to thousands of sanitary maintenance hardware items. If you need something specific, please contact us. We will find the item and get a quote for you.

Items include but not limited to:

- Auto-faucet systems
- Enviro-conscious items
- Floor machines
- Office supplies
- Packaging Supplies
- Storage & Material Handling
- Urinal screens/mats
- Vacuums
- Waste receptacles

Insecticides

BUG BUSTER (#AI41) Insect killer. A water-based insecticide formulated with the synthetic pyrethroid, Resmethrin and Esbiothrin SBP-1382® to be highly effective on flying and crawling insects. The powerful mist spray provides a wide coverage with fast knockdown. A cherry blossom fragrance makes it pleasant to use. This product is an excellent choice for use in food handling and processing facilities. Can be used for both inside and outside applications. USDA F1.

Cherry Blossom Fragrance

12-20 oz. cans per case.



FOGGING INSECTICIDE PF (#LI5G) PF Fogging Insecticide PF is designed for use in a fogging or misting machine. Fogging Insecticide PF is perfect for fogging or space spraying of growing houses, food processing plants, bakeries, restaurants, etc. Fogging PF is a synergized Pyrethrum ready-to-use in equipment designed to deliver a true aerosol mist. Pyrethrins are natural insecticides found in daisy-like Chrysanthemum flowers grown and harvested in Kenya, Africa and Australia.

Fogging Insecticide PF Features: * Repells most insects * Safe for use in food plants * Satisfactory usage around mammals and birds * Pyrethrin and the synergists are biodegradable * Rapidly disintegrate in sunlight and air

Fogging Insecticide PF Uses: * Use in a fogging machine * Use in a misting machine * Perfect in growing houses, food processing plants, bakeries, restaurants, etc. * Food processing establishments * On animals to protect beef and dairy cattle and horses



FOGGER, CARE TRI-JET (#F575): Chemical fogger or humidity control is simple with the “Tri-Jet” Fogger. The combination of adjustable valve and the tornado action nozzle allows you to maximize mist up to 30 feet directionally. The versatility of this unit allows you to fog with both water and oil base materials and may be used either indoors or outdoors. Works with the Fogging Insecticide PF.



**See next page for more insecticide solutions.*

Insecticides (Cont.)



STERI-FAB (#LG8) Sterifab acts as a contact kill on bed bugs and other insects using a combination of a synthetic pyrethroid insecticide and isopropyl alcohol. Sterifab also acts as a bactericide, fungicide, sanitizer, viricide, mildewcide, germicide, deodorant, bacteriostatic, and fungistatic. Because Sterifab does not leave any residual, it can be applied virtually anywhere. Simply shake well, then apply to desired treatment areas. Insect mortality is imminent for those contacted with Sterifab spray. Disinfection generally occurs within 10 minutes of spraying.

Steri-Fab is considered a professional do-it-yourself pest control (diy), exterminator and extermination pesticide, chemical and bug killer treatment products to spray, exterminate and eliminate pests.



Recommended Dispensing Option

HANDEE™ PUMP UP SPRAYER (#F515) Portable, heavy-duty pump-up sprayer for dispensing cleaning solutions in areas with no water hose connection. The economical choice to a mobile cleaning system.



*Other insecticide products are available.
Please contact us for further information.

Types of Liners

Advantages of Linear Low Density Can Liners

1. Maximum puncture and stretch resistance compared to High Density
2. Multi-purpose applications
3. Most prevalent type of film used in the industry today.
4. Manufactured in a wide variety of colors.
5. Compared to traditional low density film, linear low can be run at a lighter gauge with equal strength.

Advantages of High Density Can Liners

1. HMW/HD liners are about 3 times stronger and more durable than ordinary polyethylene liners of the same thickness.
2. HMW/HD liners require two-thirds less petroleum based raw material to manufacture. Accordingly, they can be made about one-third the thickness of ordinary low density polyethylene liners, so they require only about one-third the ordinary shipping, storage and warehousing cost.
3. Substantial cost savings per liner.
4. When they are properly made, HMW/HD liners will rarely “zipper” if punctured.
5. Extremely wide range of temperature resistance from -40 degrees F to +212 degrees F (boiling).
6. USDA and FDA approved (natural colored liners).

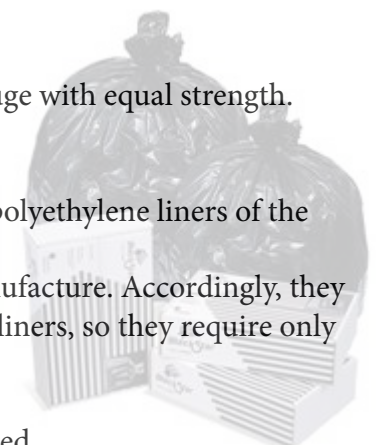

Most Popular Liners - High Density

LINER, 24X33 8M NATUR, 1000/CS (#CL_24330MC): 12-16 gallon capacity, 20 lb max load

LINER, 30X37 16M NATUR, 250/CS (#CL_30373MC): 20-30 gallon capacity, 75 lb max load

LINER, 33X40 16M NATUR, 250/CS (#CL_33403MC): 33 gallon capacity, 75 lb max load

LINER, 40X48 16M CLEAR, 250/CS (#CL_40483MC): 40-45 gallon capacity, 75 LB max load

*Other sizes available in High Density. Please contact us for a specific size, max load, gallon capacity, etc., that may not be listed here.

Most Popular Liners - Liner Low Density

LINER, 24X23 0.35ML BLK 500/CS (#CL_B72410K): 10 gallon capacity, 15 lb max load

LINER, 23X32 .45 ML WHITE 500CS (#CL_MT33W): 12-16 gallon capacity, 30 lb max load

LINER, 24X32 1.1ML BLK 250/CS (CL_TM33T): 12-16 gallon capacity, 60 lb load

LINER, 30X36 .65 ML BLK 250/CS (#CL_B73720K): 20-30 gallon capacity, 50 lb max load

LINER, 30X36 0.97ML WHT 200/CS (#CL_MT37W): 20-30 gallon capacity, 65 lb max load

LINER, 30X36 .65 CLEAR, 250/CS (#CL_P3715C): CLEAR liners are useful for recycling bins and other reasons to be able to view the contents in the bag. 20-30 gallon capacity, 30 lb max load

LINER, 30X36 BIODEGRADABLE, 150/CS (#CL_BS30G) 100% biodegradable and compostable Meets ASTM D6400 standard for compostable plastics. 20-30 gallon capacity, 60 lb max load

*See more Linear Low liners on next page



Most Popular Liners - Liner Low Density

LINER, 33X39 .95ML 150/CS (#CL_MT40W): 33 gallon capacity, 65 lb max load

LINER, 33X39 1.1ML GRAY 100/CS (#CL_RX403XG): 33 gallon capacity, 75 lb max load

LINER, 40X46 .95 ML WHITE 100/CS (#CL_MT48W):
40-45 gallon capacity, 65 lb max load

LINER, 40X46 1.8ML BLK 100/CS (#CL_TM48T):
40-45 gallon capacity, 90 lb max load

LINER, 40X46 BIODEGRADABLE., 150/CS (#CL_BS45G):
100% biodegradable and compostable
Meets ASTM D6400 standard for compostable plastics. Printed with the BioStar logo and ASTM D6400 certification.
40-45 gallon capacity, 60 lb max load

LINER, 39X47 1.7ML SILVER 50CS (#CL_TI3947S):
Titanium Can Liner (see picture). Hi-tech look, upscale silver liner. Recommended for food processors and areas exposed to clients.
40-45 gallon capacity, 95 lb max load

LINER, 42.5X48 1.1 ML GRY 100/CS (#CL_RX493XG):
56 Glutton, 75 lb max load

LINER, 38X58 0.97ML WHT 100/CS (#CL_MT60W):
60 gallon capacity, 65 lb max load

LINER, 38X58 .95ML CLEAR, 100/CS (#CL_P6530C):
CLEAR liners are useful for recycling bins and other reasons to be able to view the contents in the bag.
60 gallon capacity, 65 lb max load

LINER, 38X58 1.1ML GRY 100/CS (CL_RX653XG):
60 gallon capacity, 75 lb max load

LINER, 39X57 1.7ML SILVER 50CS (#CL_TI3957S):
55-60 gallon capacity, 95 lb max load

LINER, 36X58 1.8ML BLACK 50/CS (#CL_TM60T):
55 gallon capacity, 90 lb max load



***Don't know what size liner you need?**

Try the LinerSelector on the next page or contact us at 800-835-9501. We'll gather some information about your trash bin and determine the correct liner for you.

*The liners listed on this page are the most commonly purchased liners that Care Labs, Inc. typically carries in stock. However, it is not the complete line. If you would like us to stock and quote a specific spec liner that you do not see in our listing, please contact us at 800-835-9501 and we will get you a quote and add the liner to our stocked line.

Do you find yourself struggling to get a good fit from your can liner? The length's not right or maybe the bag is too big or too small. It's not easy to guess which bag fits which container just right, not to mention perfectly. Now you don't have to worry about a bad fit. With the Fit Can Liner System, finding the right bag for your receptacle couldn't be easier. We've put together a list of can liners for the most common trash receptacles. You find your receptacle below and listed to the right you will find all of our can liners that fit just right.

Wastebasket: 7-10 Gallon

Liner Sizes: LL 22 x 25 • HD 22 x 25



LLDPE	HDPE
.35 Mil - Black	6 Micron - Natural
.35 Mil - Clear	
Eco•Strong	
.9 Mil - Black	

Round Container: 22 Gallon

Liner Sizes: LL 29 x 44 • HD 29 x 44



LLDPE	HDPE
.95 Mil - Clear	16 Micron - Natural
1.0 Mil - Gray	
Eco•Strong	
1.2 Mil - Black	
1.5 Mil - Black	

Round Receptacle: 32 Gallon

Liner Sizes: LL 33 x 44 • HD N/A



LLDPE	HDPE
.65 Mil - Black	Not Available
.65 Mil - Clear	
.85 Mil - White	
Eco•Strong	
1.2 Mil - Black	
1.5 Mil - Black	

Wastebasket: 12-16 Gallon

Liner Sizes: LL 24 x 32 • HD 24 x 33



LLDPE	HDPE
.35 Mil - Black	6 Micron - Natural
.35 Mil - Clear	6 Micron - Black
.4 Mil - Gray	8 Micron - Natural
.45 Mil - White	
.7 Mil - Clear	
.9 Mil - Black	
Eco•Strong	
.9 Mil - Black	

Step-On Container: 32 Gallon

Liner Sizes: LL 30 x 46 • HD N/A

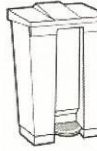

LLDPE	HDPE
.75 Mil - Black	Not Available
Eco•Strong	
Not Available	

Round Receptacle: 44 Gallon

Liner Sizes: LL 37 x 50 • HD 37 x 50



LLDPE	HDPE
.7 Mil - Black	14 Micron - Natural
.7 Mil - Gray	16 Micron - Natural
.95 Mil - White	
1.1 Mil - Black	
1.1 Mil - Clear	
Eco•Strong	
1.2 Mil - Black	
1.5 Mil - Black	

Torpedo: 15 Gallon

Liner Sizes: LL 26 x 43 • HD N/A

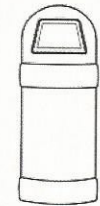

LLDPE	HDPE
.8 Mil - Black	Not Available
Eco•Strong	
Not Available	

Indoor Square Container: 23 Gallon

Liner Sizes: LL 29 x 44 • HD 29 x 44

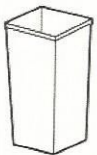

LLDPE	HDPE
.95 Mil - Clear	16 Micron - Natural
1.0 Mil - Gray	
Eco•Strong	
1.2 Mil - Black	
1.5 Mil - Black	

Round Receptacle: 55 Gallon

Liner Sizes: LL 41 x 54 • HD 41 x 54



LLDPE	HDPE
.7 Mil - Gray	16 Micron - Natural
.95 Mil - Clear	
Eco•Strong	
1.2 Mil - Black	
1.5 Mil - Black	

Torpedo: 25 Gallon

Liner Sizes: LL 29 x 44 • HD 29 x 44

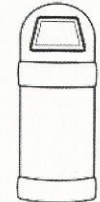

LLDPE	HDPE
.95 Mil - Clear	16 Micron - Natural
1.0 Mil - Gray	
Eco•Strong	
1.2 Mil - Black	
1.5 Mil - Black	

Indoor Square Container: 35 Gallon

Liner Sizes: LL 37 x 50 • HD 37 x 50

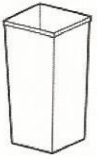

LLDPE	HDPE
.7 Mil - Black	14 Micron - Natural
.7 Mil - Gray	16 Micron - Natural
.95 Mil - White	
1.1 Mil - Black	
1.1 Mil - Clear	
Eco•Strong	
1.2 Mil - Black	
1.5 Mil - Black	

Outdoor Container: 56 Gallon

Liner Sizes: LL 42.5 x 48 • HD 43 x 48



LLDPE	HDPE
.7 Mil - Black	12 Micron - Natural
.7 Mil - Clear	14 Micron - Natural
.7 Mil - Gray	16 Micron - Natural
.75 Mil - White	16 Micron - Black
.85 Mil - White	22 Micron - Black
.95 Mil - Black	
.95 Mil - Clear	
.95 Mil - White	
1.1 Mil - Gray	
1.3 Mil - Clear	
1.8 Mil - Black	
Eco•Strong	
1.2 Mil - Black	
1.5 Mil - Black	
1.7 Mil - Black	

Slim Jim®: 23 Gallon

Liner Sizes: LL 29 x 44 • HD 29 x 44



LLDPE	HDPE
.95 Mil - Clear	16 Micron - Natural
1.0 Mil - Gray	
Eco•Strong	
1.2 Mil - Black	
1.5 Mil - Black	

Square Container: 28 Gallon

Liner Sizes: LL 40 x 46 • HD 40 x 48



LLDPE	HDPE
Multiple	Multiple
Eco•Strong	
Multiple	

King Can®: 65 Gallon

Liner Sizes: LL 50 x 43.5 • HD N/A



LLDPE	HDPE
1.1 Mil - Black	Not Available
1.1 Mil - Clear	
Eco•Strong	
Not Available	

***Don't know what size liner you need?**

Contact us at 800-835-9501. We'll gather some information about your trash bin and determine the correct liner for you.

Liners / Trash Bags (Cont.)

* New Item * - QuickDraw Liners

Now there's no need to knot the bag or use clumsy twist ties with the easy-open/close Quick Draw can liner. Quick Draw can liners feature a convenient drawstring closure and flat bottom construction which allows you to use the full capacity of the bag. The drawstring helps keep hands clean and creates a handy carry handle. These liners are designed to fit the container without waste, adding more capacity, and are constructed with no bottom seal to help prevent leakage. Uniquely packaged on an interleaved coreless roll for added convenience.



- * Convenient Drawstring Closure
- * Fits containers without waste
- * Available in black and white
- * Furnished on interleaved coreless rolls

STOCK NO.	SIZE	GALLON CAPACITY	STRENGTH	GAUGE	MAX LOAD	QTY/CS
#CL_DT10W	24 X 28	10-15 Gallon	Heavy .85 mil	50 Lbs	White	250/cs
#CL_DT33K	33 X 39	20-33 Gallon	Extra Heavy	1 mil	60 Lbs Black	150/cs
#CL_DT33W	33 X 39	20-33 Gallon	Extra Heavy	1 mil	60 Lbs White	150/cs
#CL_DT44K	37 X 46	40-45 Gallon	Extra Heavy	1.2 mil	75 Lbs Black	100/cs
#CL_DT55K	41 X 46	55 Gallon	Extra Heavy	1.2 mil	75 Lbs Black	100/cs

Mattress (Fabric) Sanitizer



STERI-FAB (#LG8) In compliance with most state bedding laws, including the Texas Bedding Law, Steri-Fab is an approved sanitizer for mattresses. Steri-Fab also serves as a mattress insecticide for bed bug treatment.

Used to kill bed bugs and prevent them. Sold in pints and gallons.



STERI-FAB SPRAYER(#F515S) In compliance with secondary labeling requirements for dispensing chemical products in a secondary container, this heavy-duty pump up sprayer allows for a continuous action spray in covering mattresses properly and thoroughly with Steri-Fab.



*Tags are available for sale for mattress manufacturers and resalers. Please contact us for pricing/availability.

Odor Digester / Eliminator



ZAPS IT (#LE2) ZAPS IT™ is a powerful odor digester and organic stain remover. ZAPS IT™ dissolves and digests waste residues, stains and malodors caused by urine, feces, vomit, blood, food wastes and other organic matter. It was created utilizing the best bio-technology and modern chemistry to build a product that achieves successful results where other products may disappoint or fail to perform.

Sold in quarts, gallons, and pails.

ZAPS-IT™ is NOT simply a deodorizer. ZAPS-IT™ is a blend of friendly bacteria which remain inactive in the bottle. When sprayed on a problem area, the solution penetrates into porous surfaces, grouting, cracks and hard to reach areas. Upon contact with residues of urine, feces, vomit, blood, food soils and other organic wastes enzymes begin breaking down the odor-forming organics into liquids. The bacteria then convert the absorbed organics into carbon dioxide and water which quickly dissipate. While this process is taking place, the pleasant fragrance of ZAPS-IT™ provides immediate relief from bad odors.



SUPER-SORB LIQUID SPILLS ABSORBENT (#O200)

Absorbs 60 times its weight immediately! Easy, sanitary disposal of blood, vomit, urine and other liquids from hard surfaces. Saves cleanup time— simply sprinkle granular absorbent onto spills, sweep up. Quat and micro-biocide eliminate odors. Ideal for use in grocery stores, restaurants, hospitals, nursing homes, day care facilities, health clinics, etc. Includes six cans of 12 ounces each.



CARE KNOCKOUT™ DEODORIZER(#LDCXX):

A powerful, broad-spectrum deodorizer which quickly and effectively eliminates the most severe odor problems. KNOCKOUT™ is economical and also an excellent environmental choice. One gallon does the work of 12 or more aerosols. This saves in product use-cost, inventory overhead, storage space and it reduces the number of discarded containers which go to landfills. Our dispensing system eliminates the use of flammable or ozone-depleting propellant gases. In addition, our adjustable spray pattern nozzle is a convenient advantage in many applications.

*Just need a general deodorizer? Try Care Knockout™

Available in the following fragrances:

Fresh: #LDC10

Cherry: #LDC2

Baby Powder: #LDC4

Cups

CUP, DART 8 OZ FOAM (#P100)

8 oz
White
Insulated
25 Ea/Slv, 40 Slv/Ctn
One-piece molded construction, distinctive pedestal and space-saving design.



CUP, DART 16 OZ FOAM (#P101)

16 oz
White
Insulated
25 Ea/Slv, 40 Slv/Ctn
One-piece molded construction, distinctive pedestal and space-saving design.



CUP, SPRING GROVE COFFEE 12 OZ (#P102)

12 oz, Beige, Standard, Style: Spring Grove Design (50 Each/Sleeve, 20 Sleeve/Case)



CUP, PLASTIC SEE-THRU 5 OZ (#P103)

5 oz see-thru plastic cups.
2500/case.



Kleenex Tissue

#21400 KLEENEX FACIAL TISSUE WHT, 36/CS (#P107) 8-2/5" W x 9" L, 2 Ply, 100 Sht/Box, 36 Box/Ctn. This facial tissue delivers premium quality, preferred for superior softness, strength and absorbency.

SPRING GROVE FACIAL TISSUE, FLAT BOX (#P107A): Spring Grove tissue offers the right blend of quality, performance and value to meet your needs. 7.8" W x 8" L, White
100 Sht/Box, 30 Box/Ctn

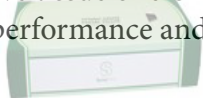

*More paper items on next page.

Folded Towels- Multi

ACCLAIM FOLDED TOWEL, MULTI-FOLD 4,000/CS (#P110): 9-1/4" W x 9-1/2" L, 1 Ply, White, Paper, 250 Sht/Pkg, 16 Pkg/Ctn
Economy Folded towels for reliable performance at a low cost.

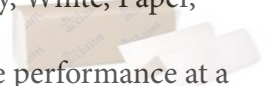

SIGNATURE FOLDED TOWEL, MULTI-FOLD (#P112): A premium 2-ply hand towel that provides the softness and absorbency your patrons and tenants will appreciate. 9-1/4" W x 9-1/2" L, 2 Ply, White Paper, 125 Sht/Pkg, 16 Pkg/Ctn



SPRING GROVE FOLDED TOWEL, NATURAL MULTI-FOLD (#P117): 9.1" W x 9.25" L, Natural, Paper
250 Ea/Pkg, 16 Pkg/Ctn



SPRING GROVE FOLDED TOWEL, WHITE MULTI-FOLD (#P119): 9.1" W x 9.5" L, White, Paper
250 Ea/Pkg, 16 Pkg/Ctn



Folded Towels- Single

SPRING GROVE FOLDED TOWEL, SINGLE FOLD (#P118A): 9" W x 9.4" L, Natural, Paper
250 Ea/Pkg, 16 Pkg/Ctn



SCOTT FOLDED TOWEL, SINGLE FOLD: Depend on Scott Towels for reliable performance. 9-3/10" W x 10-1/2" L, 1 Ply, White, Paper
250 Sht/Pkg, 16 Pkg/Ctn



*The items listed on this page are the most commonly purchased items Care Labs, Inc. carries in stock. However, it is not the complete line. If you would like us to stock and quote a specific paper item that you do not see in our listing, please contact us at 800-835-9501 and we will get you a quote and add the item to our stocked line.

Roll Towels

ENVISION ROLL TOWEL, ROLL 26401 (#P120): High capacity, economical, hardwound roll towels fit into a wide variety of everyday, universal towel dispensers. 7-7/8" W x 350' L, 1.625" Core, 1 Ply Brown Paper, 12 Rl/Ctn

PREFERENCE ROLL TOWEL, PERFORATED (#P121): Popular 2-ply perforated roll towels offer reliable performance for everyday cleaning and wiping tasks. 11" W x 8-4/5" L, 1.625" Core, 2 Ply, White Paper, 85 Sht/RL, 30 Rl/Ctn.

SPRING GROVE ROLL TOWEL, F/KITCHEN, 30/CS (#P123): 8.8" W x 11" L, 85-Count, White Paper 85 Sht/RL, 30 Rl/Ctn.

SPRING GROVE ROLL TOWEL, HARDWOUND (#P125): 7-3/4" W, White Paper, 12 Rl/Ctn

Toilet Tissue

ENVISION GEORGIA-PACIFIC 19880 TOILET TISSUE, ROLL (#P130): An economical choice for environmentally concerned customers with high-traffic washroom areas. Ideal for washrooms in public facilities, schools, industrial/manufacturing, retail stores, and cafeterias/quick service restaurants. 4" W x 4.05" L, 2 Ply, White Paper, 550 Sht/RL, 80 Rl/Ctn

SCOTT TOILET TISSUE, STANDARD ROLL (#P134): Scott Bathroom Tissue is the reliable and practical choice. 4" W x 4-1/10" L, Standard, 2 Ply, White Paper, 550 Sht/RL, 80 Rl/Ctn

SPRING GROVE TOILET TISSUE, STANDARD ROLL (#P138): 3-1/4" W x 4-1/2" L, 2 Ply, white Paper 500 Sht/RL, 96 Rl/Ctn

SPRING GROVE TOILET TISSUE, JUMBO ROLL (#P139): 9" Dia, Jumbo, 2 Ply, White Paper 12 Rl/Ctn

ACCLAIM TOILET TISSUE, ROLL JUMBO (#P136): 9" Dia, Jumbo, 2 Ply, White Paper, 12 Rl/Ctn

Food Trays

SPRING GROVE FOOD TRAYS: One-piece nested food tray in various designs and sizes.

Small (Size 50), 1,000/cs: #P140
Medium (Size 200), 1,000/cs: #P141
L:arge (Size 500), 500/cs: #P142

Wipes - Industrial

WYPALL WORKHORSE RAG, BRAG BOX X70 (#P151A): Absorbent wipers that stay strong for better cleaning performance. Reusable, long lasting performance. Cleans oil, grime, and solvents. Made with our high-tech HYDROKNIT Fast Absorbing Material. Ideal for all manufacturing and maintenance & repair. X70, 12-1/2" W x 16-4/5" L, Heavy Duty 1 Ply, White, HydroKnit, 152 Sht/Box, 1 Box/Ctn

**More Wipes and paper goods on next page.*

*The items listed on this page are the most commonly purchased items that Care Labs, Inc. typically carries in stock. However, it is not the complete line. If you would like us to stock and quote a specific paper item that you do not see in our listing, please contact us at 800-835-9501 and we will get you a quote and add the item to our stocked line.

Wipes - Industrial (Cont.)

WYPALL REINFORCED WIPER, POP UP BOX 34790 (#P150): X60 wipers bring the absorbing power of our HYDROKNIT material technology to a light weight wiper, combining versatile performance and economy for light-duty tasks. X60, 9-1/10" W x 16-4/5" L
4 Ply, White, Terry, 126 Sht/Box, 10 Box/Ctn

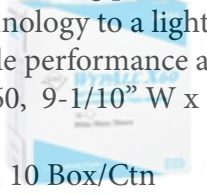

WYPALL WIPER, 1/4-FOLD, ALL PURPOSE (#P151): Ideal for routine industrial cleaning and maintenance. Removes soils and liquids from face and hands.
L40, 12-1/2" W x 13" L, 1 Ply, White
Double Recrepe Paper, 56 Sht/Pkg, 18 Pkg/Ctn



Food Service Items

SPRING GROVE 9" PAPER PLATES, 1M/CS (#P160)

FORKS, MEDIUM-QUALITY 1M/CS (#1BWKY)

KNIVES, MEDIUM-QUALITY 1M/CS (#1PPKN)

SPOONS, MEDIUM QUALITY 1M/CS (#1GENPPTS)

Dispensers for Paper Goods

IN-SIGHT SANITOUCH ROLL TOWEL DISPENSER: Improved stub-roll feature, quieter sound, shorter sheet-size for better economy and a design that makes it easier to see the tail of paper. Translucent plastic design lets you see inside to know when re-fills are needed. 12.75" W x 16.5" H x 10.25" D
Smoke Gray, Plastic, Touch Free
8" dia Roll of SCOTT or Kleenex HRT Towels

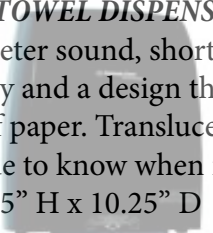

SPRING GROVE FOLDED TOWEL DISPENSER

Translucent Black, C-Fold/Multi-Fold
Economical and dependable.



Specialty Products



LUBES-ALL™ (#GFG1D) is a special **polymer reinforced white food grade grease** with outstanding load carrying ability and excellent high temperature performance. Because of its unique combination of ingredients, nearly all of the requirements of the food processing, and other industries that require a lubricant for use with incidental food contact, can be met.

The wide operating temperature range (00 – 4500F) and high load carrying ability make LUBES-ALL™ a super performer, having excellent rust, oxidation and water resistance. It is especially formulated for high load, superior adhesion, excellent anti-wear and high temperature performance. This exceptional multi-purpose food machinery grease finds use in a multitude of applications including the normal lubricating grease functions as well as serving as a release agent, anti-rust agent and gasket and seal agent.

Sanitizers

CARE SUR-SAN™ (#LG15) SUR-SAN™ is designed for use in food processing plants, schools, animal quarters and kennels where disinfection, sanitization and deodorization is of prime importance. When used as directed, SUR-SAN is formulated to disinfect hard, non-porous, inanimate environmental surfaces: floors, walls, metal surfaces, stainless steel surfaces, glazed porcelain, glazed ceramic tile, plastic surfaces, bathrooms, shower stalls, bathtubs, cabinets, tables, chairs and telephones.

When applied at 1 ounce per 4 gallons, Sur-San is a no-rinse sanitizer.



BIOSAN 7.5M is a 7.5% active quaternary ammonium chloride developed for all types of industries requiring effective disinfectant, sanitizer, fungicide and deodorizer. BIOSAN 7.5M when applied at 150 p.p.m. does not require a potable water rinse.

Wipes - Disinfectant

CAVIWIPES: Low Alcohol (17.20% isopropanol) Surface Disinfectants.

Presaturated with CaviCide®, CaviWipes is a cleaner and disinfectant, in one. CaviWipes are durable, nonwoven, nonabrasive towelettes that offer quick, easy-to-use, time-saving convenience. They're recommended for use on non-porous surfaces and fixtures.

Ideal for operating rooms, surgical centers, neonatal units, medical and dental operatories and other critical-care areas. CaviWipes should not be disposed of in the toilet.

Features:

1. Effective against Staphylococcus aureus with reduced susceptibility to vancomycin and Influenza A2 Virus
2. Kills TB in 3 minutes and MRSA, HIV-1 and HBV and HCV in 2 minutes.
3. Saves time and inventory. A cleaner and disinfectant in one.
4. Stays fully saturated. Better fluid capacity means the wipes won't dry out.
5. Convenient. Ready-to-use towel and CaviCide in one.
6. Nonabrasive. For use on nonporous surfaces.
7. Superior surface contact. Durable, nonwoven towels won't bunch up during use
8. Flat Packs minimize storage space, unclutter counter space, and are resealable

CaviWipes, 160ea 6x6.75 12/cs (Regular size): #M805

CaviWipes XL 66ea 10x12, 12/cs (Large wipes): #M804

